

Art. #, TS 93 GSR Series & G-EMF Channel (DHW), 05/2022 EN.
Subject to change without notice



Contact Us
Info.ASEAN@dormakaba.com
www.dormakaba.com.sg



Door Hardware



Electronic Access & Data



Mechanical Key Systems



Lodging Systems



Entrance Systems



Interior Glass Systems



Safe Locks



Service

dormakaba Singapore Pte Ltd
12 Tukang Innovation Drive #04-01
Singapore 619303
T +65 6268 7633

dormakaba Malaysia Sdn Bhd
No. 3, Jalan TP 6
Taman Perindustrian UEP
47600 Subang Jaya
Selangor Darul Ehsan
T +603 8081 8009

dormakaba Philippines Inc.
Unit 102 RCI Building,
105 Rada St.,
Legaspi Village, Makati City, Philippines
T +632 8993 4077/78

dormakaba (Thailand) Limited
762/2 Room no. A25B,
Rama 3 Road Bangpoo-pang,
Yannawa Bangkok 10120, Thailand
T +66 2059 2612

PT. dormakabaAccess Indonesia
Ruko Jalan Ciputat Raya No. 335,
Desa/Kelurahan Kebayoran Lama Utara,
Kec. Kebayoran Lama, Kota Adm. Jakarta
Selatan, Provinsi DKI Jakarta,
Indonesia, 12240
T +62 21 2930 3762

dormakaba Vietnam Rep Office
Centec Business Center, Unit 002, Floor 4,
72-74 Nguyen Thi Minh Khai Street,
Ward 6, District 3, Ho Chi Minh City,
Vietnam
T +84 8 62 99 82 72

GSR Series G-EMF / EMR Channel

G-EMF slide channel with electro-mechanical hold-open

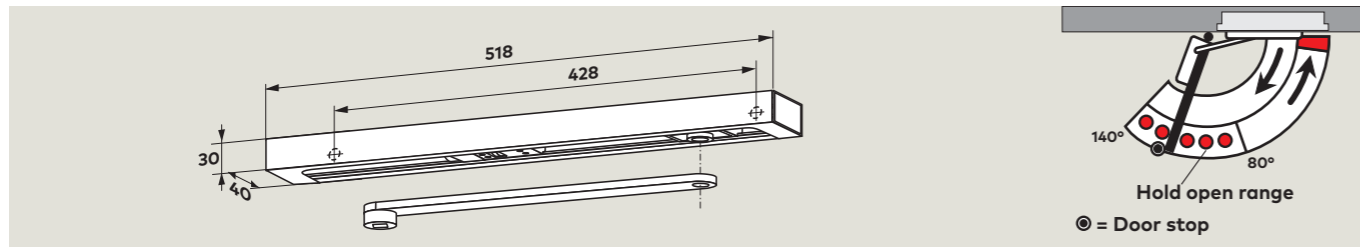

The **G-EMF** slide channel assembly enables the door to be held open securely at a preselected position without fall-back. The hold-open point can be adjusted within an opening angle of approx. 80° and 140°.

Note
The active leaf can be opened up to the maximum selected hold-open point (door stop to be positioned accordingly).

In the event of an alarm or a fault in the power supply, the hold-open is released and the door is closed by the door closer. The release is triggered by a signal from external smoke detectors (e.g. RMZ or RM). The release force for the hold-open mechanism can be adjusted without tools and is rated to ensure that the door can also be easily released manually. The G-EMF slide channel assembly comprises the slide arm, slide channel, slide block, electro-mechanical hold-open unit, cover, fixing screws and end caps. The G-EMF is transom-fixed and non-handed.

In the case of particularly large and heavy doors (over 1250 mm), or doors in which the hold-open point required exceeds 140°, we recommend that EM hold-open magnets in conjunction with the RMZ central smoke detector be employed instead of the electro-mechanical hold-open unit.

Technical data

Operating voltage	24 V DC, ± 15%
Power input	1.4 W
Rated for continuous duty	100% ED
Release force	adjustable

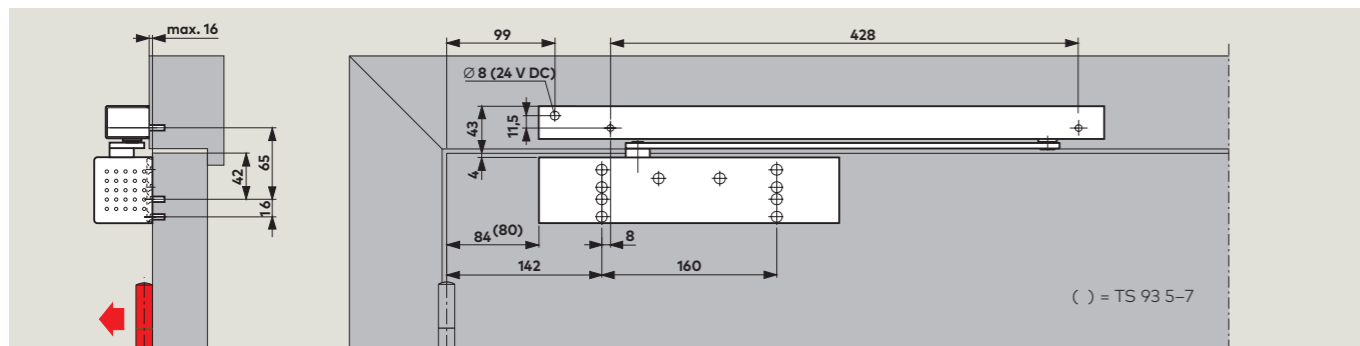

TS 93 B closer with G-EMF slide channel assembly, pull-side fixing
Example: Anticlockwise-closing (ISO 6) door; mirrored arrangements apply to clockwise-closing (ISO 5) doors.

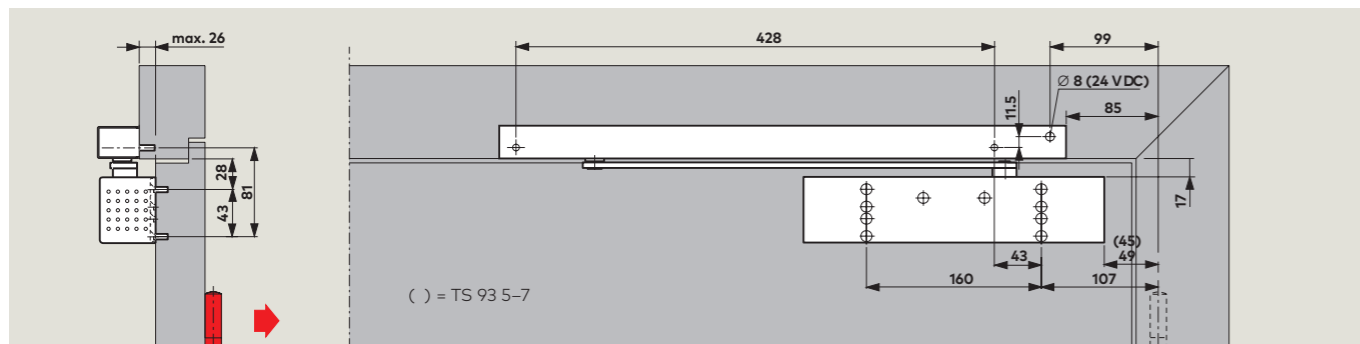

TS 93 G closer with G-EMF slide channel assembly, push-side fixing
Example: Anticlockwise-closing (ISO 6) door; mirrored arrangements apply to clockwise-closing (ISO 5) doors.

F Approval certification

The TS 93 EMF has been successfully type-tested to EN 1155, Electrically Powered Hold-Open Devices. Certificates are available on request.

Regulations/Information

The use of hold-open devices may be subject to certain conditions – see page 27.

Example application

Hold-open system on a fire and smoke door, comprising: TS 93 B door closer, G-EMF slide channel assembly, RMZ (smoke sensor, release switching unit and stabilised power pack for 24 vDC) as frame-mounted smoke detector, plus one RM-N smoke detector on both sides of the door. (See also page 22.)

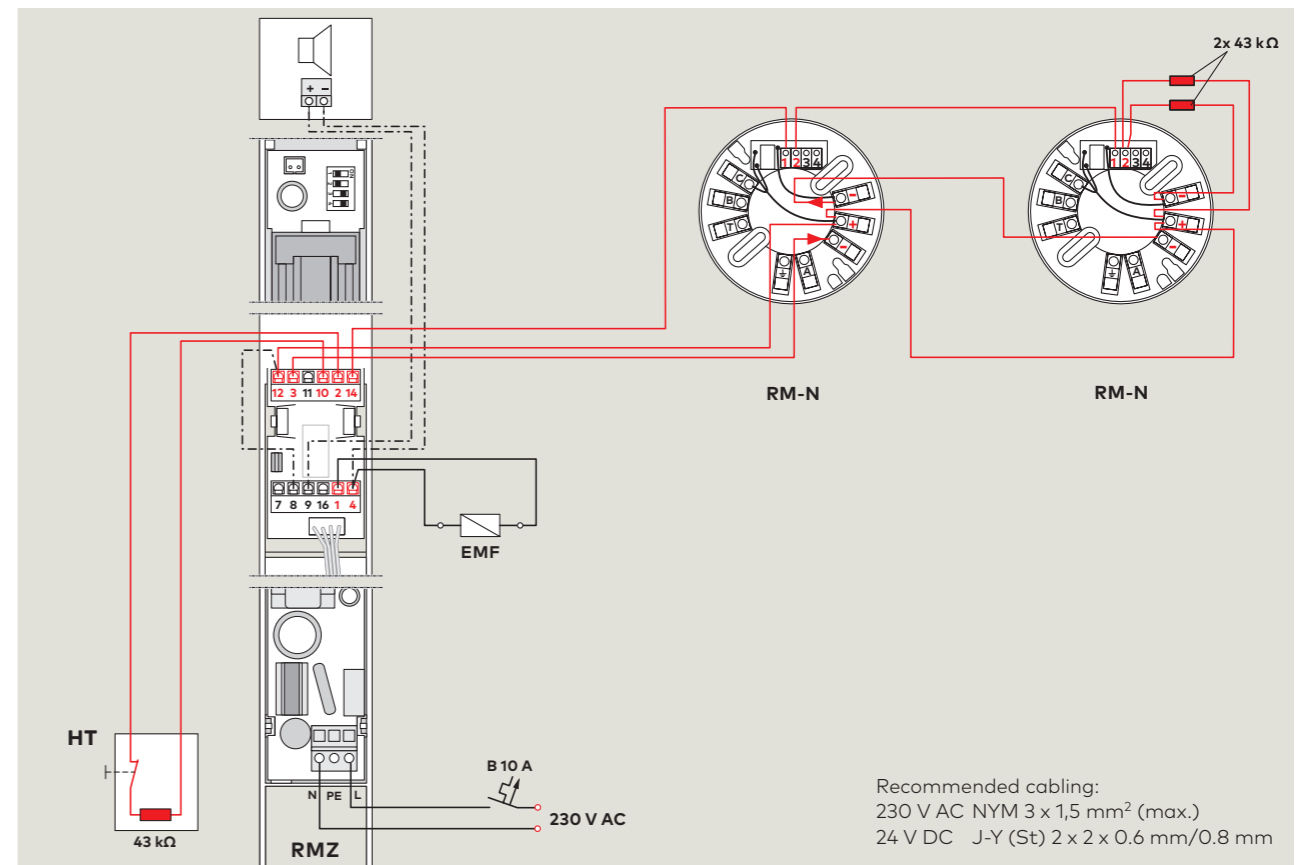
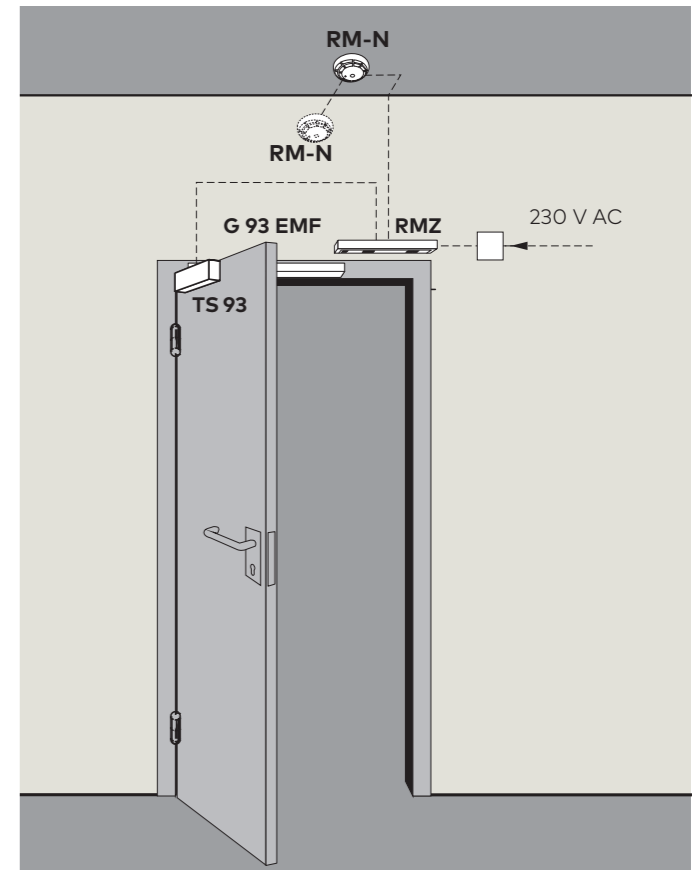

Recommended cabling:
230 V AC NYM 3 x 1,5 mm² (max.)
24 V DC J-Y (St) 2 x 2 x 0.6 mm/0.8 mm

G-SR door co-ordinator slide channel Pull side fixing

The G-SR slide channel with integral door co-ordinator featuring a push rod clamping system for **double doors**, ensures that the active leaf always closes after the inactive leaf. As this system operates independently of the door closer hydraulics, it offers maximum safety and reliability (doors prevented from "creeping closed"). An overload release protects both the door co-ordinator and the door set from damage. The G-SR door co-ordinator is non-handed and suitable for combination with TS 93 B door closers.

Unter entsprechenden baulichen Voraussetzungen ist bei dieser Montageart ein Öffnungswinkel von 180° möglich. In den meisten Fällen ist dabei eine Wandausnehmung für den Türschliesser vorzusehen.

ÜBERSETZUNG

F Approval certification

The TS 93 G-SR has been successfully type-tested to EN 1158, Door Co-ordinator Devices. Certificates are available on request.

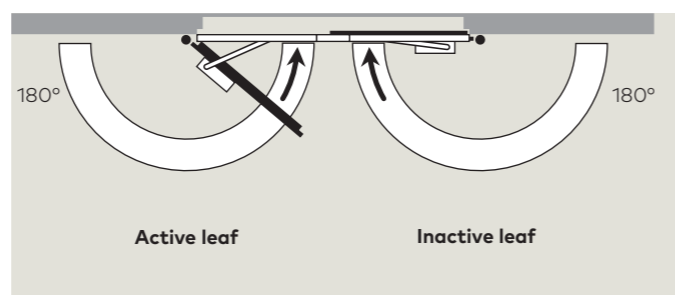
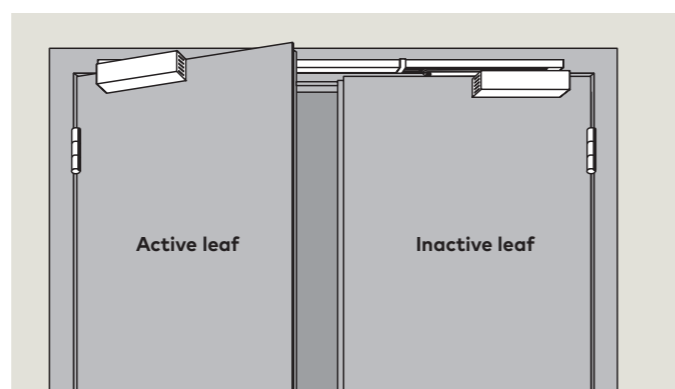

G-SR-EMF with electro-mechanical hold-open G-SR-EMR with integral smoke detector

These door co-ordinators not only ensure the correct closing sequence of double doors, but also allow the door leaves to be individually held open. In the event of an alarm or power failure, the hold-open is released and the door is closed by the door closer. The release action is triggered by a signal from the smoke detector integrated in the G-SR-EMR door co-ordinator.

The G-SR-EMR door co-ordinator model is also available without a power pack for integration in building management and control systems via the TMS door management system. The pull-off force for the hold-open mechanism can be adjusted without tools and is rated to ensure that the door can also be easily released manually. G-SR-EMF and G-SR-EMR door co-ordinators are non-handed and suitable for combination with TS 93 B door closers. In the case of doors in which the hold-open point required exceeds 130°, we recommend that EM hold-open magnets be applied instead of the electro-mechanical hold-open unit.

Regulations/Information

The use of hold-open devices may be subject to certain conditions – see page 27.

The smoke detector unit has to be replaced after 8 years according to DIN 14677. Having reached the replacement time, a light-emitting diode will light continuously.

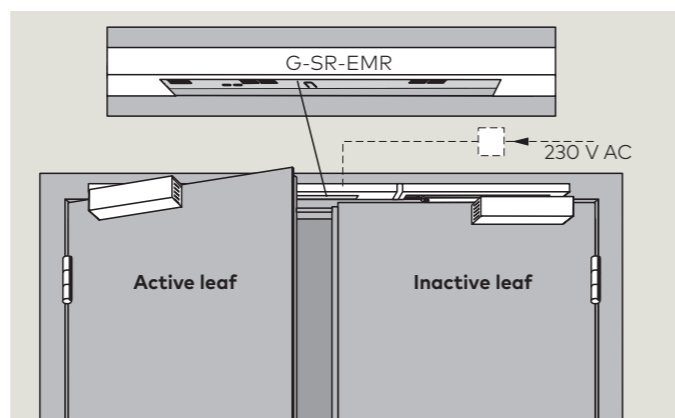
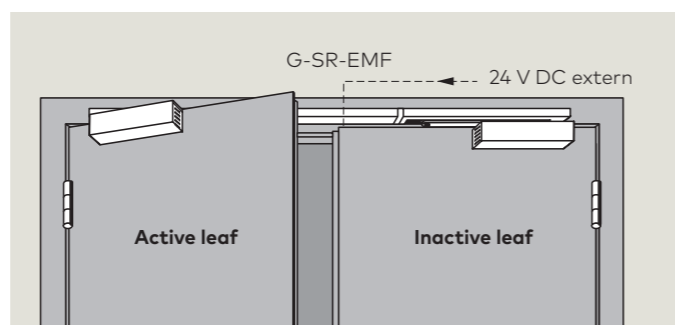

G-SR-EMF 1

This door co-ordinator contains just one hold-open mechanism, located in the inactive leaf slide channel, for holding open both door leaves. The single-point hold-open position is adjustable between approx. 80° and 130°.

Note

The active leaf can be opened up to the maximum selected hold-open point (door stop to be positioned accordingly). The active leaf can be held open by the door co-ordinator at any angle up to max. 150°.

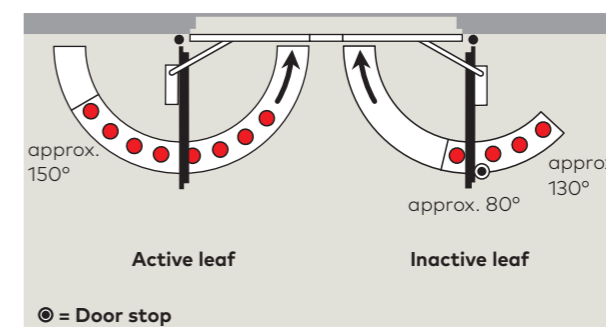

G-SR-EMF 2

With this door co-ordinator, the active leaf can be held open independently of the inactive leaf. The hold-open points for each leaf lie between approx. 80° and 130°.

Note

The active leaf can be opened up to the maximum selected hold-open point (door stop to be positioned accordingly).

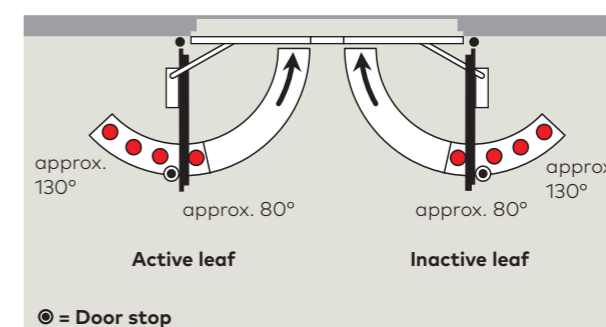

G-SR-EMF 1G

This door co-ordinator enables the active leaf to be held open independently in special door sets involving, for example, fixed side screens, narrow inactive leaves („penny farthing“ doors), etc. The hold-open point lies between approx. 80° and 130°.

Note

The active leaf can be opened up to the maximum selected hold-open point (door stop to be positioned accordingly).

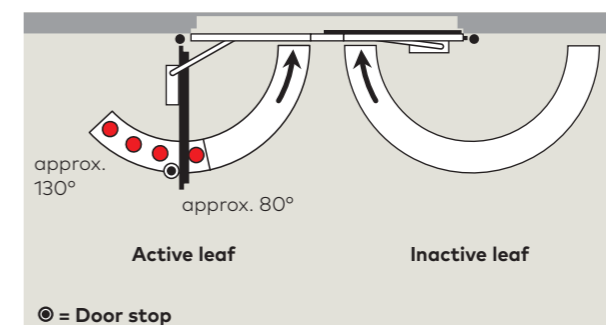

F Approval certification

The TS 93 G-SR-EMF 1, EMF 2 and EMF 1G have been successfully type-tested to EN 1155, Electrically Powered Hold-Open Devices. Certificates are available on request.

G-SR-EMR 1

This door co-ordinator includes an integral smoke detector. A floating (volt-free) alarm contact and connections for further detectors and external manual release devices are also provided. Technical data for smoke detectors: see page 22.

G-SR-EMR 2

This door co-ordinator includes an integral smoke detector. A floating (volt-free) alarm contact and connections for further detectors and external manual release devices are also provided. Technical data for smoke detectors: see page 22.

G-SR-EMR 1G

This door co-ordinator includes an integral smoke detector. A floating (volt-free) alarm contact and connections for further detectors and external manual release devices are also provided. Technical data for smoke detectors: see page 22.

Technical data

Power supply	EMR	230 V AC ± 10%
Max. output rating	EMR	9.8 W
Operating voltage	EMF	24 V DC, ± 15%
Power input	EMF 1	1.4 W
	EMF 2	2.8 W
Rated for continuous duty		100% ED
Release force		adjustable

F Approval certification

The TS 93 G-SR-EMR 1, EMR 2 and EMR 1G have been successfully type-tested to EN 1155, Electrically Powered Hold-Open Devices. Certificates are available on request.

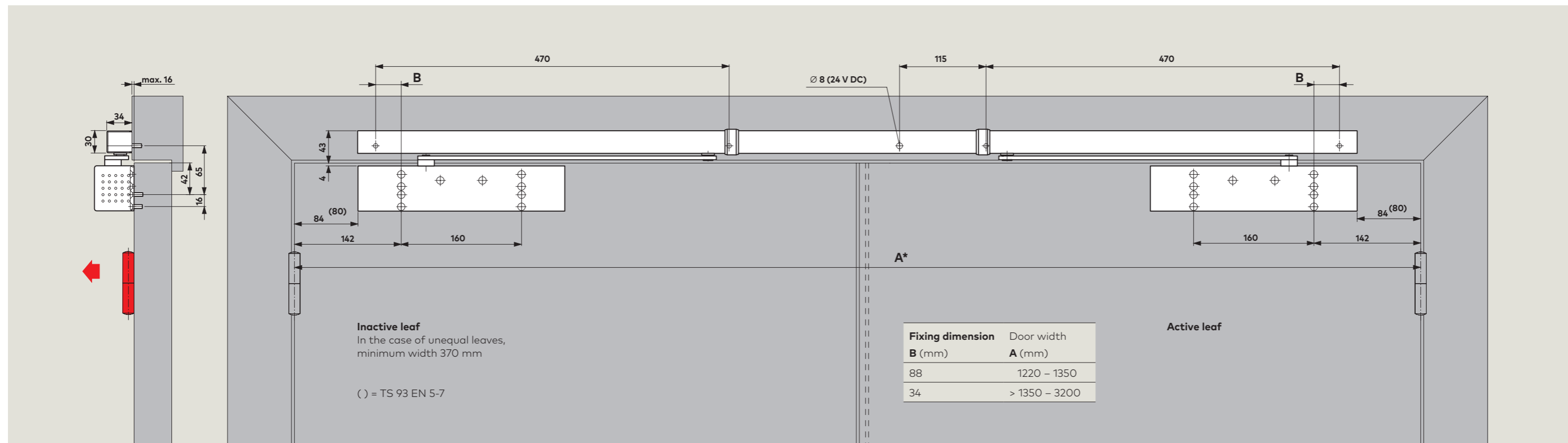

Door co-ordinator **TS 93 B** with electro-mechanical hold-open G-SR/G-SR-EMF, pull side fixing

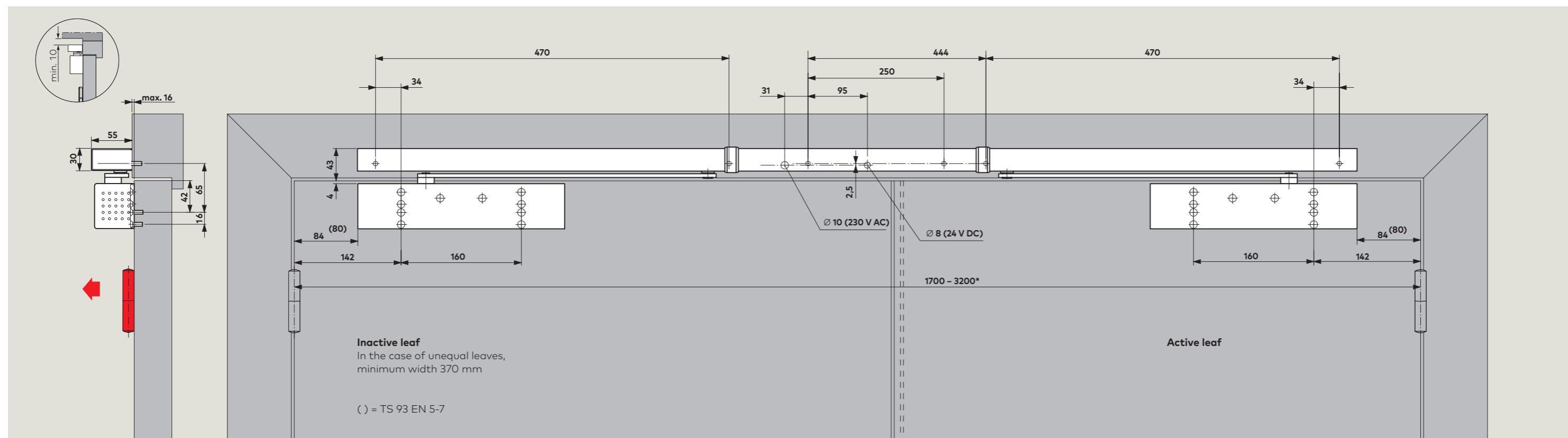

Door co-ordinator **TS 93 B** with integral smoke detector G-SR-EMR, pull side fixing

* In the case of particularly large and heavy doors (over 2500 mm), we recommend that EM hold-open magnets be employed instead of the electro-mechanical hold-open unit.

G-SR/BG slide channel door co-ordinators Push side fixing

The G-SR/BG push-side slide channel with integral door co-ordinator, featuring a push rod clamping system for **double doors**, ensures that the active leaf always closes after the inactive leaf. As this system operates independently of the door closer hydraulics, it offers maximum safety and reliability (doors prevented from "creeping closed"). An overload release protects both the door co-ordinator and the door set from damage. The G-SR/BG door co-ordinator is non-handed and suitable for combination with TS 93 G door closers.

Note
Max. opening angle 120° (door stop to be positioned accordingly).
Not suitable for emergency exit doors which are opened at the inactive leaf.

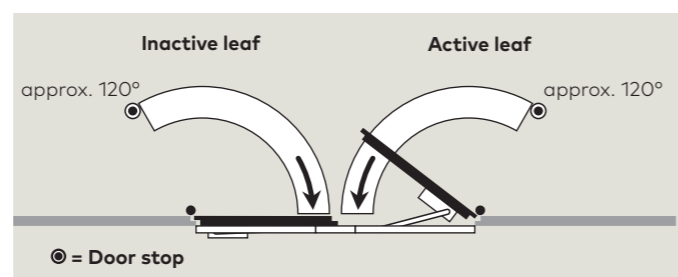
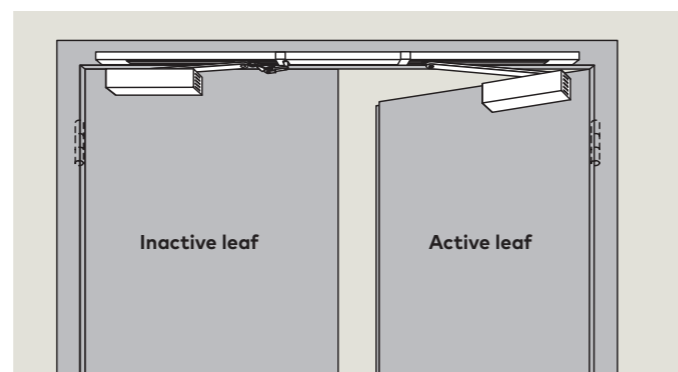

F Approval certification
The TS 93 G-SR/BG has been successfully type-tested to EN 1158, Door Co-ordinator Devices. Certificates are available on request.

G-SR-EMF 2/BG
With this door co-ordinator, the active leaf can be held open independently of the inactive leaf. The hold-open points for each leaf lie between approx. 80° and 120°.

Note
The active leaf can be opened up to the maximum selected hold-open point (door stop to be positioned accordingly).

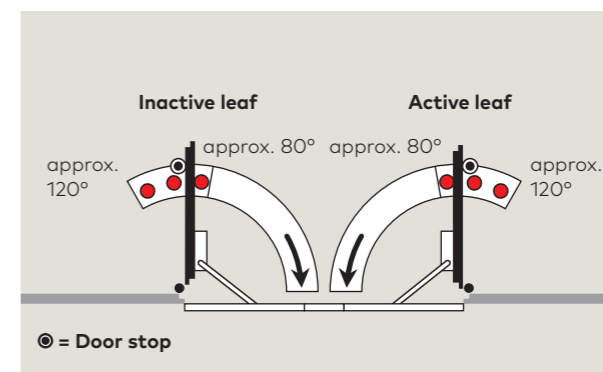

F Approval certification
The TS 93 G-SR-EMF 2/BG have been successfully type-tested to EN 1155, Electrically Powered Hold-Open Devices. Certificates are available on request.

Technical data

Power supply EMR	230 V AC ± 10%
Max. output rating EMR	9.8 W
Operating voltage EMF	24 V DC, ± 15%
Power input EMF 2	2.8 W
Rated for continuous duty	100% ED
Release force	adjustable

G-SR-EMR 2/BG
This push-side door co-ordinator includes an integral smoke detector. A floating (volt-free) alarm contact and connections for further detectors and external manual release devices are also provided. Technical data for smoke detectors: see page 22.

F Approval certification
The TS 93 G-SR-EMR 2/BG has been approved by the German Institute for Building Technology, Berlin, for use as a hold-open unit. Acceptance inspection of the system is mandatory.

G-SR-EMF/BG with electro-mechanical hold-open G-SR-EMR/BG with integral smoke detector

These push-side door co-ordinators not only ensure the correct closing sequence of double doors, but also allow the door leaves to be individually held open. In the event of an alarm or power failure, the hold-open is released and the door is closed by the door closer. The release is triggered by a signal from the smoke detector integrated in the G-SR-EMR/BG door co-ordinator.

The G-SR-EMR/BG door co-ordinator model is also available without a power pack for integration in building management and control systems via TMS door management system. The pull-off force for the hold-open mechanism can be adjusted without tools and is rated to ensure that the door can also be easily released manually. The G-SR-EMF/BG and G-SR-EMR/BG door co-ordinators are non-handed and suitable for combination with TS 93 G door closers. Not suitable for emergency exit doors which are opened at the inactive leaf.

Regulations/Information
The use of hold-open devices may be subject to certain conditions – see page 27.
The smoke detector unit has to be replaced after 8 years according to DIN 14677. Having reached the replacement time, a light-emitting diode will light continuously.

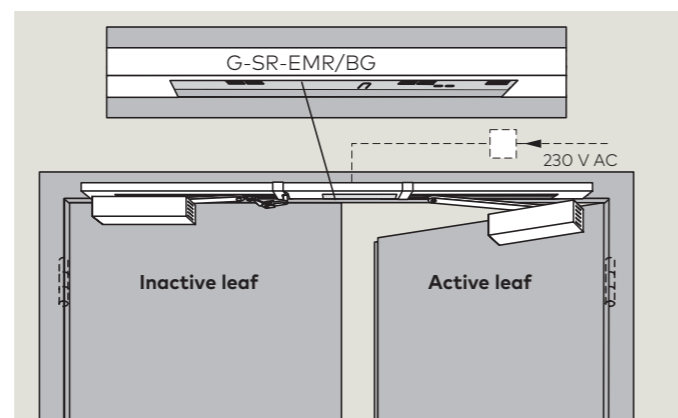
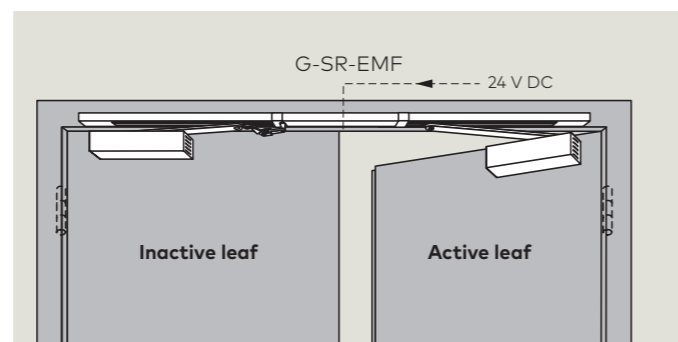

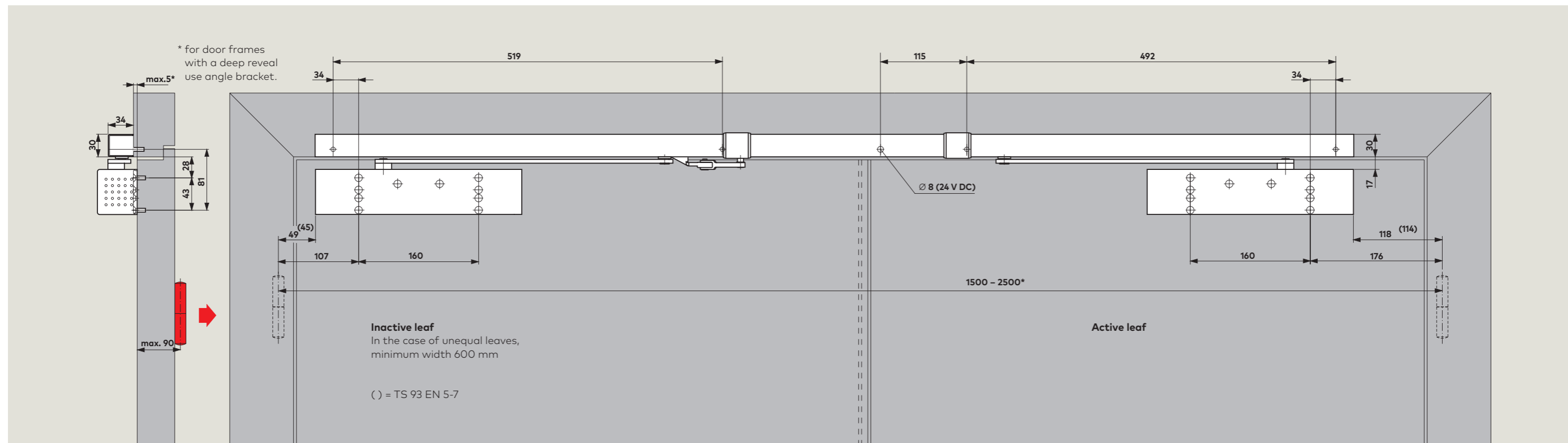

Door co-ordinator **TS 93 G** with electro-mechanical hold-open G-SR/BG / G-SR-EMF/BG, push side fixing

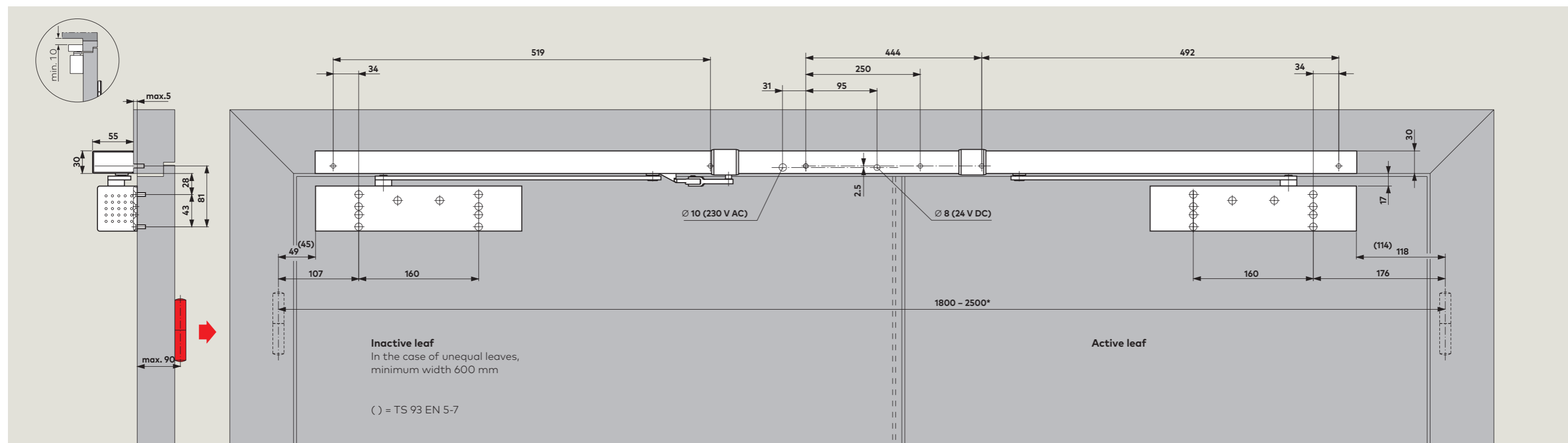

Door co-ordinator **TS 93 G** with integral smoke detector G-SR-EMR/BG, push side fixing

* In the case of particularly large and heavy doors, we recommend that EM hold-open magnets be employed instead of the electro-mechanical hold-open unit.

Smoke detectors

The RMZ and RM-N smoke detectors provide the ideal complement to the TS 93 system for passive/preventive fire protection. They are designed in accordance with the latest codes issued by the German Institute for Building Technology and ensure perfect interaction between all the devices employed for holding open fire and smoke check doors – whatever the situation.

RMZ

The RMZ smoke detector in the Contur design provides a 24V DC supply for all the hold-open devices connected to it. In the event of an alarm or power failure, it de-energises the devices (release function). It has an automatic reset which can be switched to manual mode if required. A floating (no-volt) change-over contact and connections for both further detectors and for an external manual release device are also provided. The unit is available in the RMZ version with a stabilised power pack, or in the RMZ version without a power pack for integration in building management and control systems via TMS door management system.

The smoke detector unit has to be replaced after 8 years according to DIN 14677. Having reached the replacement time, a light-emitting diode will light continuously.

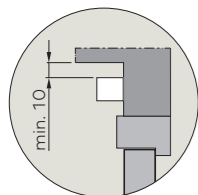
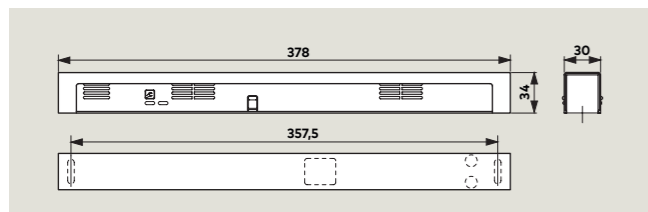

RM-N

The RM-N smoke detector ensures the early detection both of smouldering fires and open fires with smoke evolution. It can be connected to all dormakaba hold-open systems.

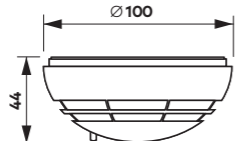

F Approval certification

The RMZ and RM-N smoke detectors have been granted general building approval by the German Institute for Building Technology, Berlin; acceptance inspection mandatory in Germany.

Data and features		RMZ	RM-N
Functions	Smoke detector Release device Power supply unit	● ● ●	● - -
Smoke detection	Scattered light principle (optical sensor)	●	●
Fixing	Lintel or transom-mounted Ceiling-mounted	● -	- ●
Connection of other detectors		●	-
Total installed load (max.) for hold-open device and other detectors in W		9.8	-
Power consumption of internal detectors in W		1.2	0.65
LED indicators	Alarm Standby Maintenance due Contaminated	● ● ● ●	● - - -
Input voltage		230 V AC ± 10 %	24 V DC +15%, -10%
Output voltage		24 V DC	-
Detector operating voltage		24 V DC +15%, -10%	24 V DC
Input current (max.) in mA		75	20
Floating (no-volt) change-over contact Safety extra low voltage (SELV)		24 V AC/DC 1 A	30 V AC/DC 1 A
Reset	Automatic Can be changed to manual reset ¹⁾	● ●	● -
Functional check	Smoke detection	●	●
Connection terminals for external manual release		●	-
Degree of protection		IP 30	IP 43
Ambient temperature in °C		-20, +40	-10, +60
Weight in kg		0.25	0.15
Dimensions in mm	Length	379	∅ 100
	Overall depth	34	44
	Height	30	
Compliant with EN 54 Part 7		●	●
CE mark for building products		●	●

● yes - no

¹⁾ Required in connection with TS 99 FL and ITS 96 FL

RMZ + 2x RM-N

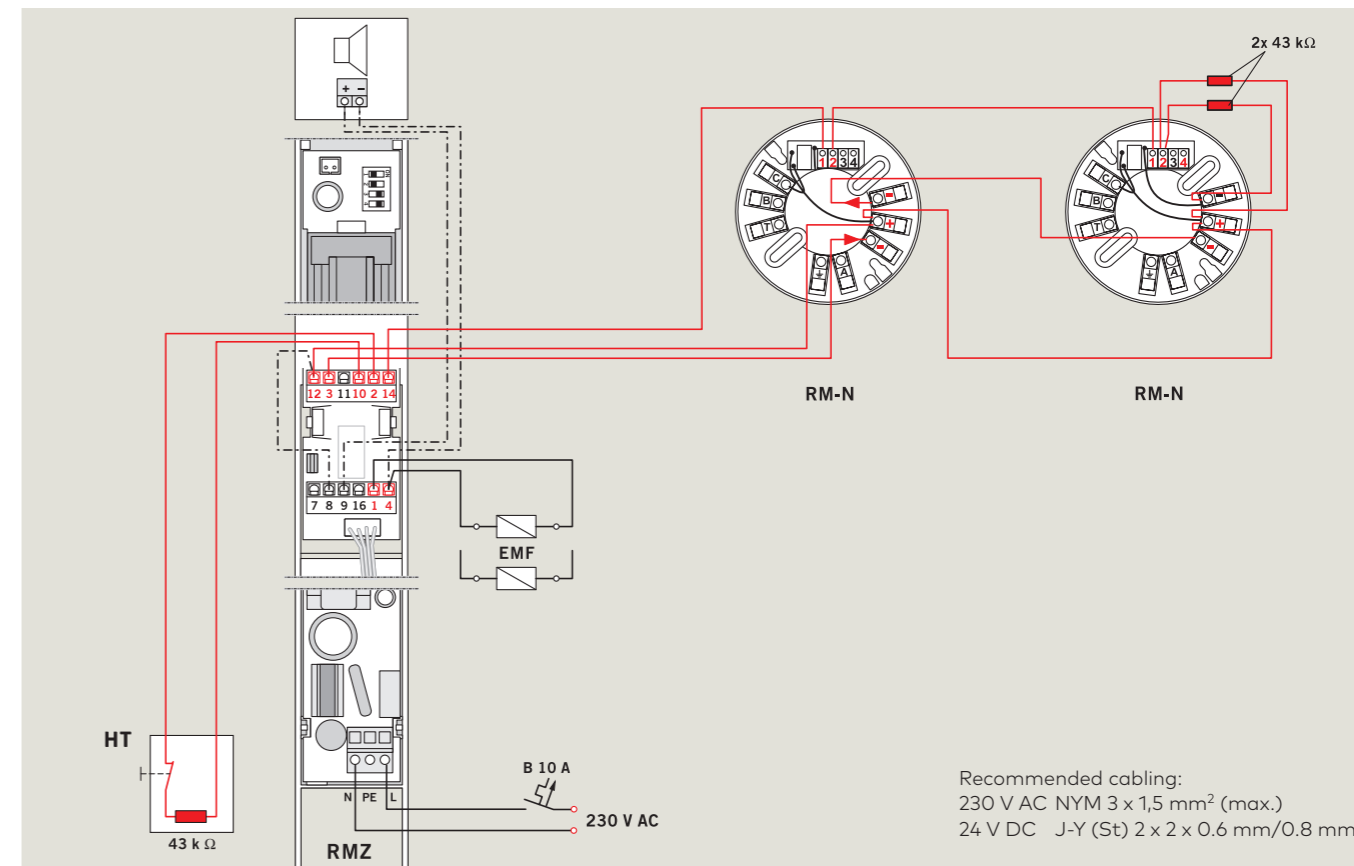

G-SR-EMR + 2x RM-N

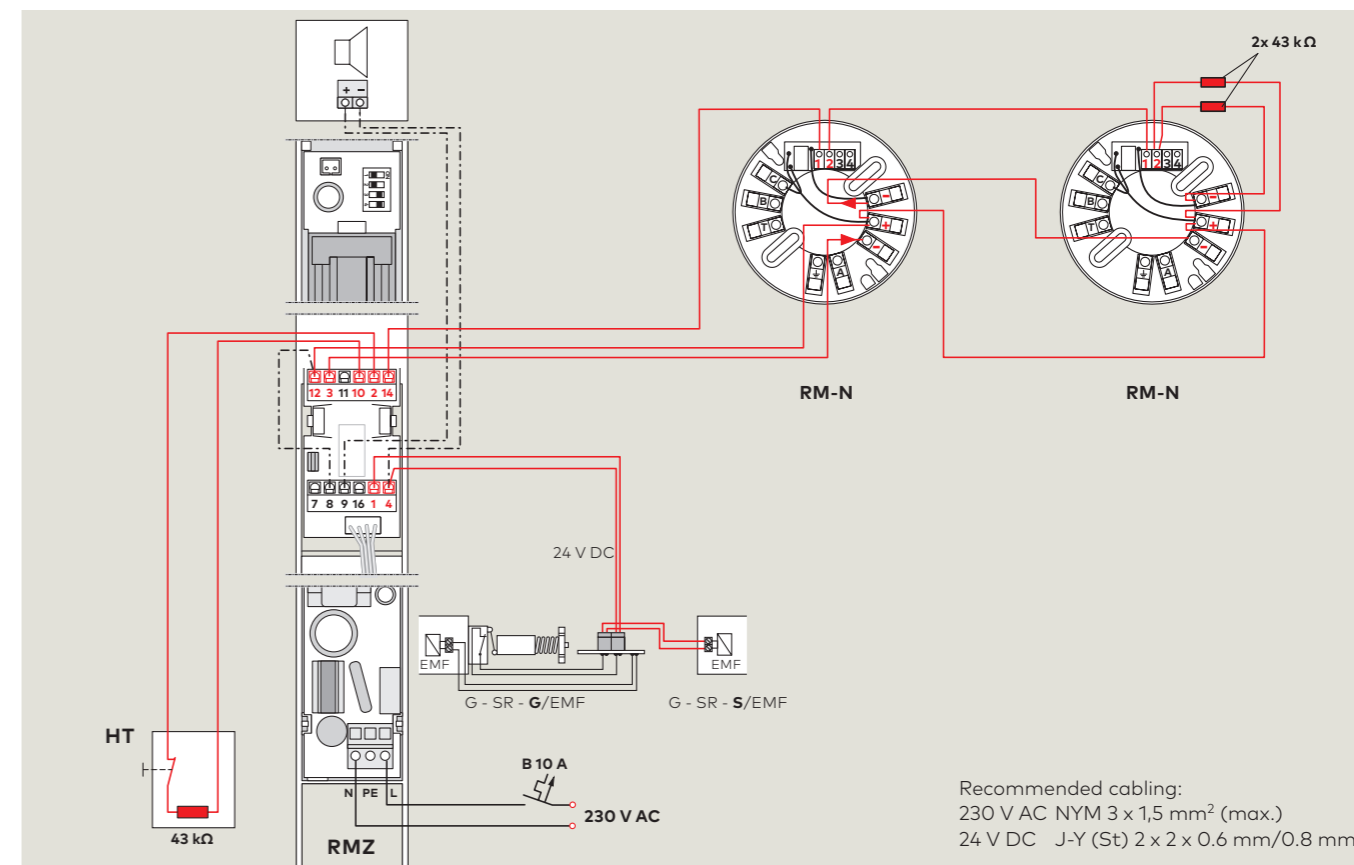

Accessories for single doors

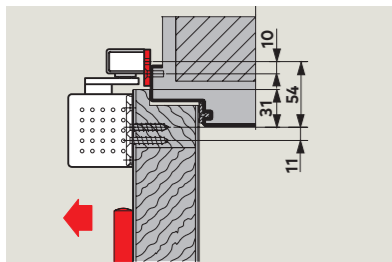

30 mm mounting backplate for G-N
For fixing the slide channel to the door frame where direct fixing is not possible.

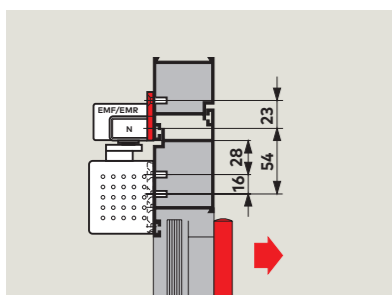
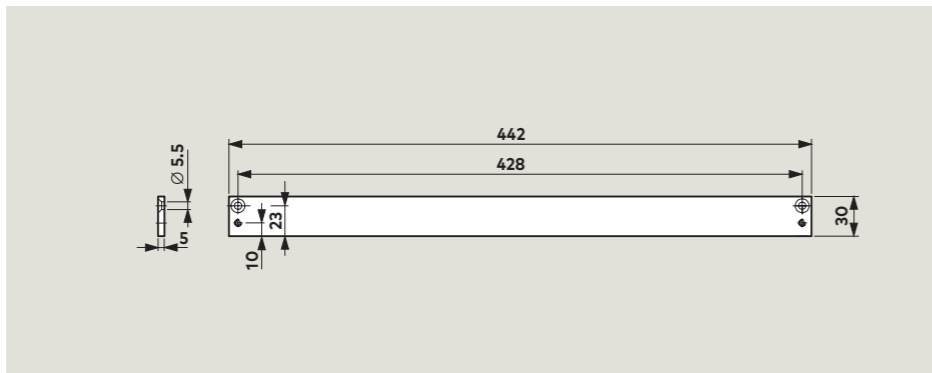

40 mm mounting backplate for G-N, EMF, EMR
For fixing the slide channel to the door frame where direct fixing is not possible.

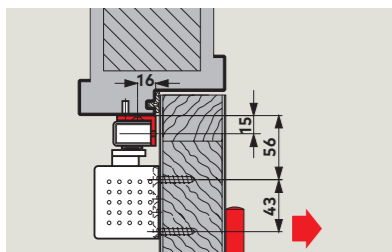
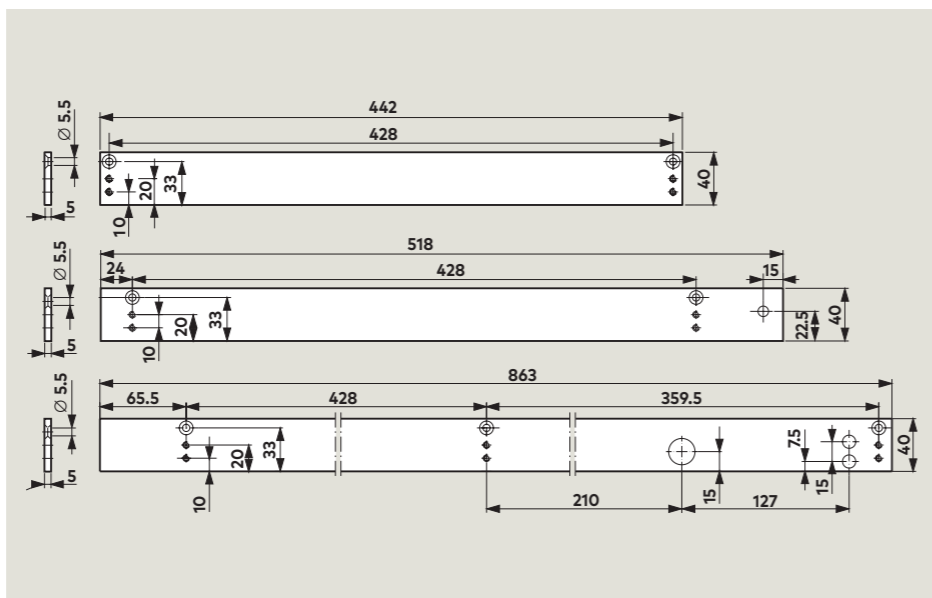

Angle bracket for G-N
For push-side fixing of the slide channel to door frames with a deep reveal.

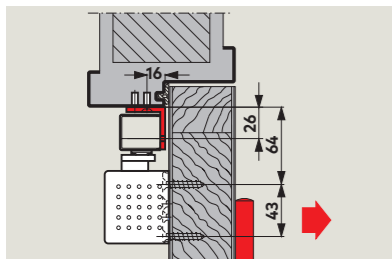
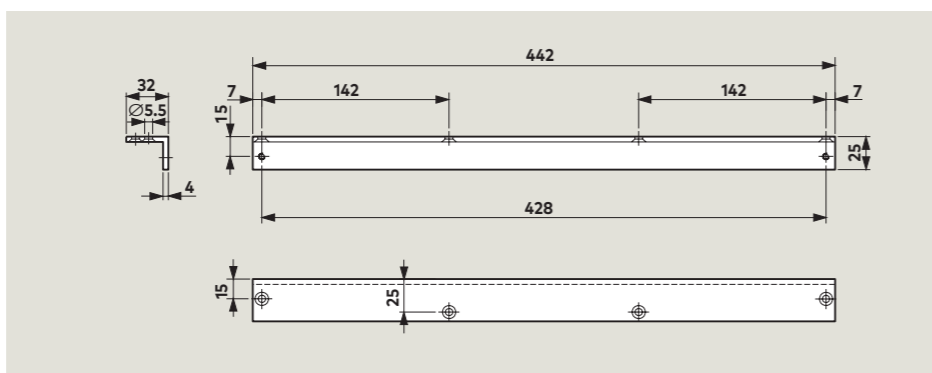

Angle bracket for G-EMF
For push-side fixing of the slide channel to door frames with a deep reveal.

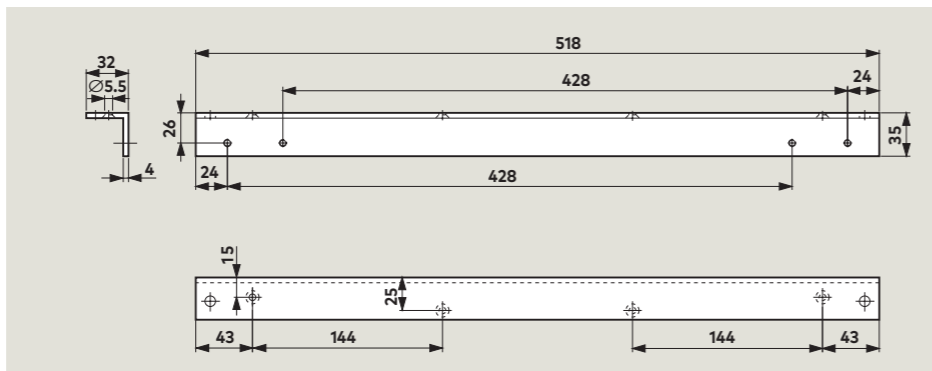

Accessories for double doors

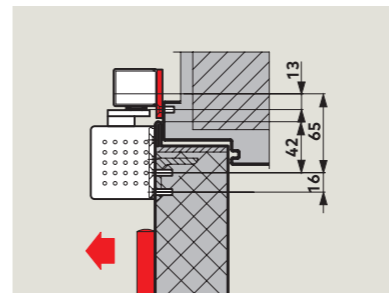

40 mm mounting backplate for G-SR
For fixing the slide channels to the door frame where direct fixing is not possible.

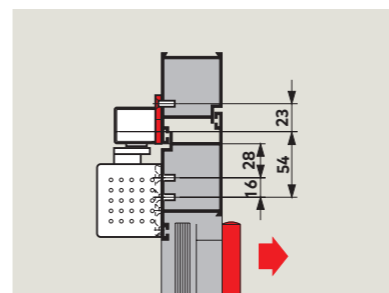
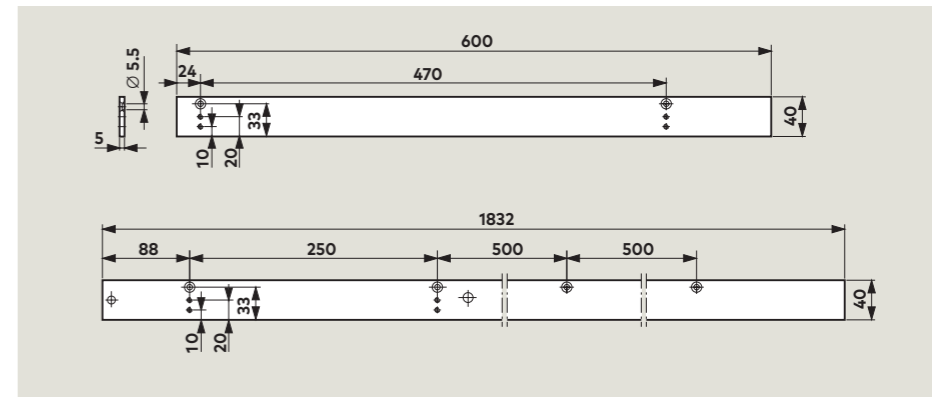

40 mm mounting backplate for G-SR/BG
For fixing the slide channels to the door frame where direct fixing is not possible.

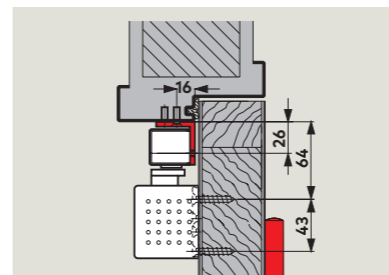
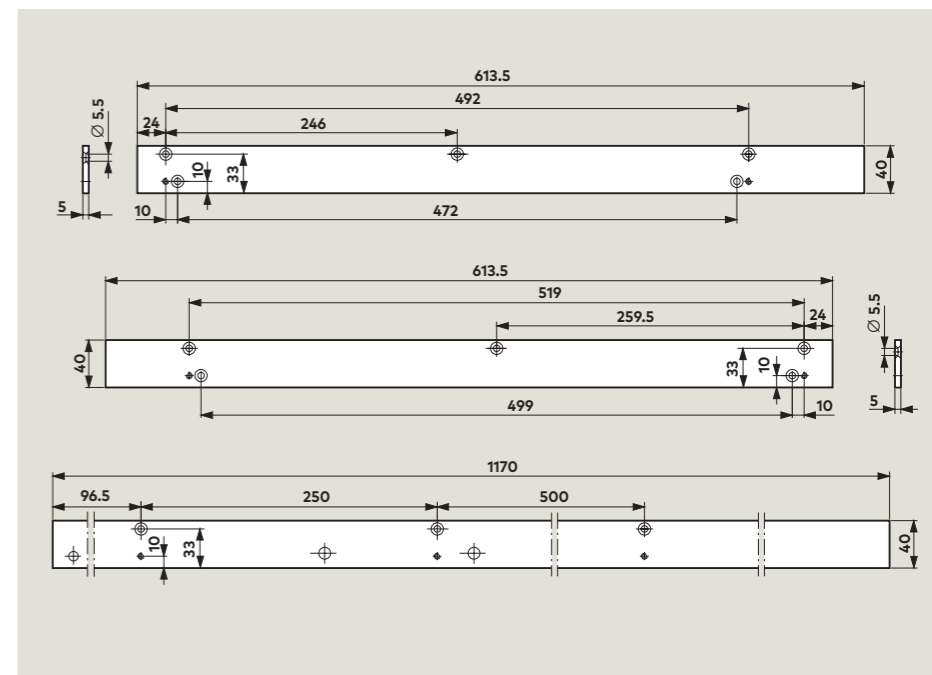

Angle bracket for G-SR/BG
For fixing the slide channels to door frames with a deep reveal.

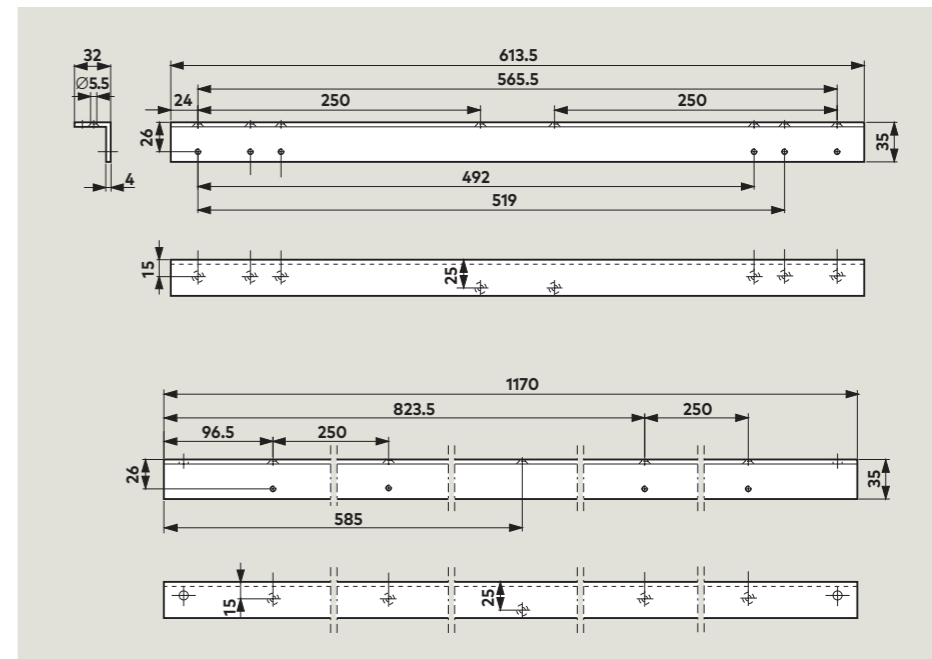

G-SR pivot block

If the G-SR door co-ordinator is to operate independently of the TS 93 door closer, for example, in combination with the ED 100/ED 250 automatic swing door operator, the connection between the door co-ordinator and the door leaf is provided by means of G-SR pivot blocks.

F Approval certification

The G-SR door co-ordinator with pivot blocks has been approved by e.g. the State Material Testing Authority, Dortmund/Germany, for use on double fire and smoke doors.

G-SR pivot block for door co-ordinator

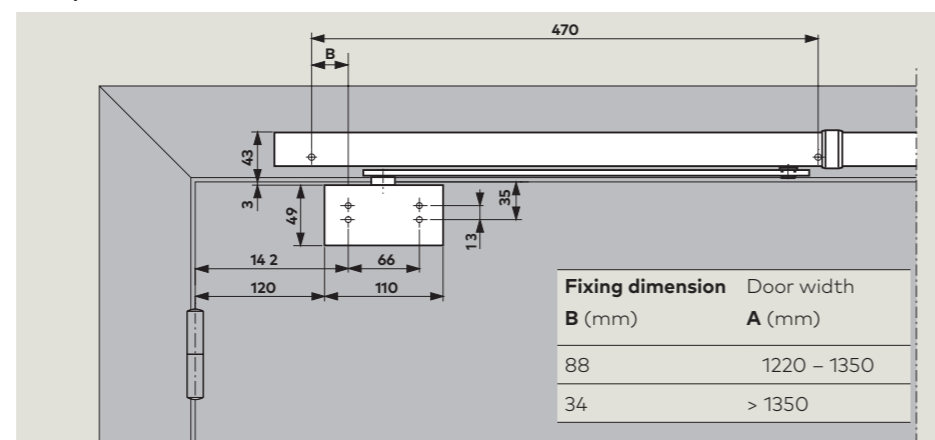

ED 100/ED 250 automatic swing door operator with G-SR door co-ordinator and G-SR pivot block

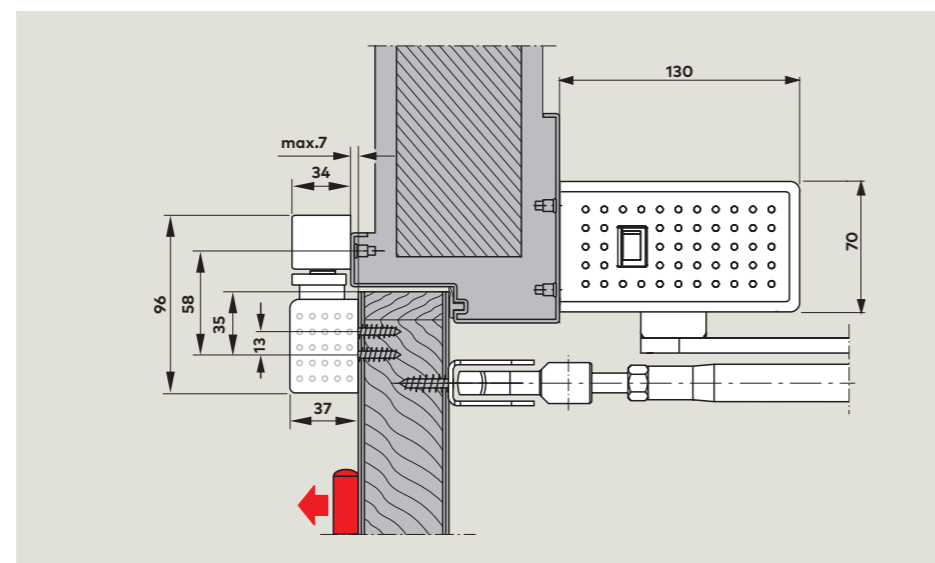

Hold-open systems Regulations/Information

The use of hold-open systems is subject to special regulations based on official approval requirements. These relate in particular to the final inspection (acceptance), continuous monitoring and maintenance.

The regulations and instructions provided below are intended as an aid, pursuant to statutory regulations that apply e.g. in Germany, to ensure that all participants are properly informed of the most important requirements that relate to the installation and operation of hold-open systems.

Further information can be found in the following documents:

- Code of practice relating to hold-open systems issued by the German Institute for Building Technology, Berlin
- General building regulations pertaining to the approval of the hold-open system concerned
- DIN EN 1155
- DIN EN 14637
- DIN 14677

1. General

1.1 In the case of fire doors (and similar shutters/closures/barriers) that are held open by hold-open systems, the sweep area necessary for the closing operation must be kept constantly clear. This area must be clearly identified by lettering, floor markings or similar. Where necessary, structural measures must also be implemented to ensure that cables, leads, lines, pipes, stored/deposited goods or components (e.g. false ceilings or other overhead items/elements) are reliably prevented from falling into the sweep area.

1.2 Wherever possible, smoke detectors should be used for hold-open systems. For hold-open systems for fire doors in emergency escape routes, smoke detectors must be used.

1.3 Each hold-open device must also be capable of being released by hand, without adversely affecting the functional capabilities of the automatic release device. In the case of door closers with electro-magnetic hold-open, the manual release may be performed by a small tug applied to the door leaf. If holding electro-magnets or free-swing door closers are used, a pushbutton must be provided to facilitate manual release. The manual release pushbuttons employed for this purpose must be red and carry the wording "Close Door" or equivalent. The pushbutton must be located in the immediate vicinity of the door and must not be concealed by the door when this is held open.

2. Commissioning

2.1 In Germany and countries governed by DIN regulations: Following on-site installation of the operable hold-open system, its functional integrity and quality of installation must be confirmed by an acceptance in-spection procedure. The acceptance inspection may only be performed by skilled personnel of manufacturers of monitoring and/or hold-open devices, skilled personnel authorized by same, or skilled personnel from an accredited inspection agency.

2.2 In Germany and countries governed by DIN regulations: Once the acceptance inspection has been successfully completed, the operator shall permanently fix on the wall, in the immediate vicinity of the door, a plate supplied by the manufacturer of the hold-open system measuring 105 mm x 52 mm and carrying the inscription:
Hold-open system
Inspected by... (company logo with month and year of acceptance inspection) or equivalent

2.3 The operator is to be provided with a certificate detailing the successful acceptance inspection; this certificate must be retained by the operator.



3. Routine Inspection

3.1 The hold-open system must be kept by the operator in a constantly good operating condition, and inspected at least once a month to ensure that it is functioning properly.

3.2 In addition, the operator is obliged at least once a year, or at shorter intervals if specified in the approval certificate, to inspect all the devices to ensure that they are operating and interacting properly and without fault, and to carry out or instigate adequate maintenance. The associated test, inspection and the maintenance work may only be performed by an expert or an appropriately trained person.

3.3 The scope, result and time of the periodic inspection are to be recorded. These records must be retained by the operator.

Range of equipment and optional accessories single doors

			TS 93 B		TS 93 G		30 mm mounting backplate for G-N	40 mm mounting backplate for G-N	40 mm mounting backplate for G-EMF	40 mm mounting backplate for G-EMR	Angle bracket for G-N	Angle bracket for G-EMF	Cushioned limit stay set for G-N	Add-on old-open unit for G-N
			2-5 ■ 430200xx 5-7 ■ 435200xx	2-5 ■ 430300xx 5-7 ■ 435300xx										
			6	7			24	24	24	24	24	24	8	8
G-N		□ 640100xx	8	□	■	□	■	△					△	△
G-EMF		□ 640800xx	10	□	■	□	■		△			△		
G-EMR		□ 640700xx	12	□	■	□	■			△				

Product description: see page

Smoke detector system

RMZ
648000xx

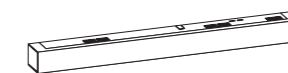

RM-N
64830900
packaging unit 2 pcs.

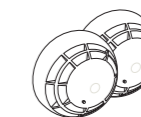

Product description: see page 22

xx Colour







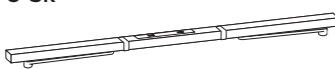

- 01 Silver
- 11 White (RAL 9016)
- 10 White (RAL 9010)
- 09 Special colour

Also available in matching "Design" finishes
04 Stainless steel

* "Design" refers to the surface finish of the products

- Hold-open device – tested to EN 1155 (max. EN 5)
- Smoke detector
- xx Colour
- Closer separate
- Slide channel assembly separate
- △ Optional accessory

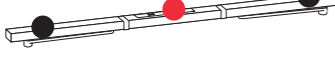
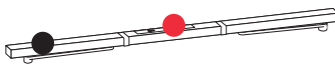
Range of equipment and optional accessories double doors

		TS 93 B		TS 93 G		Mounting backplate for G-SR	Mounting backplate for G-SR/BG	Angle bracket for G-SR/BG	Pivot block	Cushioned limit stay
		2-5	5-7	2-5		644800xx	644900xx	644700xx	645000xx	18020000
		■ 430200xx	■ 435200xx	■ 430300xx						
Active leaf	Inactive leaf	6		7		25	25	25	26	8
Product description: see page										
G-SR		<input type="checkbox"/> VK 641010xx	14	<input type="checkbox"/>	2 x ■					
		<input type="checkbox"/> V 641020xx				△				
		<input type="checkbox"/> VL 641030xx								
G-SR-EMF 1		<input type="checkbox"/> VK 641110xx	14	<input type="checkbox"/>	2 x ■					
		<input type="checkbox"/> V 641120xx				△				
		<input type="checkbox"/> VL 641130xx								
G-SR-EMF 2		<input type="checkbox"/> VK 641310xx	14	<input type="checkbox"/>	2 x ■					
		<input type="checkbox"/> V 641320xx				△				
		<input type="checkbox"/> VL 641330xx								
G-SR-EMF 1G		<input type="checkbox"/> VK 641210xx	14	<input type="checkbox"/>	2 x ■					
		<input type="checkbox"/> V 641220xx				△				
		<input type="checkbox"/> VL 641230xx								
G-SR-EMR 1		<input type="checkbox"/> V 642150xx	14	<input type="checkbox"/>	2 x ■					
		<input type="checkbox"/> VL 642160xx				△				
G-SR-EMR 2		<input type="checkbox"/> V 642350xx	14	<input type="checkbox"/>	2 x ■					
		<input type="checkbox"/> VL 642360xx				△				
G-SR-EMR 1G		<input type="checkbox"/> V 642250xx	14	<input type="checkbox"/>	2 x ■					
		<input type="checkbox"/> VL 642260xx				△				
G-SR/BG		<input type="checkbox"/> V 641440xx	18		2 x ■		△	△	△	△
G-SR-EMF 2/BG		<input type="checkbox"/> V 641740xx	18		2 x ■		△			
G-SR-EMR 2/BG		<input type="checkbox"/> V 642770xx	18		2 x ■		△			

Smoke detector system

RMZ
648000xx



RM-N
64830900
packaging unit 2 pcs.

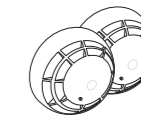

Product description: see page 22

		Door width (mm)	
		B	BG
G-SR/G-SR-EMF	VK	1220 – 1350	–
	V	> 1350 – 2500	1500 – 2500
	VL	> 2500 – 3200	–
G-SR-EMR	V	1700 – 2500	1800 – 2500
	VL	>2500 – 3200	–

Feststellvorrichtung in der Schiene geprüft nach EN 1155 bis EN 5.
Darüber hinaus Einsatz von Haftmagneten (EM 500x) möglich.

ÜBERSETZUNG

xx Colour

- 01 Silver
- 11 White (RAL 9016)
- 09 Special colour

Also available in matching "Design" finishes
04 Stainless steel

* "Design" refers to the surface finish of the products

- Hold-open device – tested to EN 1155 (max. EN 5)
- Smoke detector
- xx Colour
- Closer separate
- Slide channel assembly separate
- △ Optional accessory

Specification text single doors

TS 93 N EN 2-5 / EN 5-7

Cam action door closer conforming to EN 1154, carries the CE mark, Contur design, with rapidly decreasing opening torque/force. Door leaf fixing on the pull side, transom fixing on the push side. Closing speed, latching speed, hydraulically controlled backcheck and delayed action conveniently adjustable at valves accessible from the front.

Mounting bracket with universal fixing hole system. Non-handed. Height-adjustable slide channel.

Optional

- With retrofittable cushioned limit stay for integration in the standard slide channel.
- With retrofittable mechanical hold-open unit (RF), hold-open point adjustable between 75° and 150°.

Use of mechanical hold-open units is not permitted on fire and smoke check doors.

Colour

- silver
- white, sim. to RAL 9010 9016
- stainless steel
- special colour (sim. to RAL)

Make

TS 93 N, EN 2-5
TS 93 N, EN 5-7
TS 93 RF, EN 2-5
TS 93 RF, EN 5-7

TS 93G N EN 2-5 / EN 5-7

Cam action door closer conforming to EN 1154, carries the CE mark, Contur design, with rapidly decreasing opening torque/force. Door leaf fixing on the push side, transom fixing on the pull side. Closing speed, latching speed, hydraulically controlled backcheck and delayed action conveniently adjustable at valves accessible from the front.

Mounting bracket with universal fixing hole system. Non-handed. Height-adjustable slide channel.

Optional

- With retrofittable cushioned limit stay for integration in the standard slide channel.
- With retrofittable mechanical hold-open unit (RF), hold-open point adjustable between 75° and 150°.

Use of mechanical hold-open units is not permitted on fire and smoke check doors.

Colour

- silver
- white, sim. to RAL 9010 9016
- stainless steel
- special colour (sim. to RAL)

Make

TS 93G N, EN 2-5
TS 93G N, EN 5-7
TS 93G RF, EN 2-5
TS 93G RF, EN 5-7

TS 93 EMF EN 2-5

Cam action door closer conforming to EN 1154, carries the CE mark, Contur design, with rapidly decreasing opening torque/force. Pull-side fixing. Closing speed, latching speed, hydraulically controlled backcheck and delayed action conveniently adjustable at valves accessible from the front.

Mounting bracket with universal fixing hole system. Non-handed. Slide channel assembly with integral electro-mechanical hold-open, 24 V DC, conforming to EN 1155. Hold-open point (80° – 140°) and pull-off force infinitely variable. One-piece cover. Overall height 30 mm.

Approved by the German Institute for Building Technology, Berlin, for use in hold-open systems. Acceptance inspection of the system is mandatory.

Colour

- silver
- white, sim. to RAL 9010 9016
- stainless steel
- special colour (sim. to RAL)

Make

TS 93 EMF,
EN 2-5

TS 93G EMF EN 2-5

Cam action door closer conforming to EN 1154, carries the CE mark, Contur design, with rapidly decreasing opening torque/force. Push-side fixing. Closing speed, latching speed, hydraulically controlled backcheck and delayed action conveniently adjustable at valves accessible from the front.

Mounting bracket with universal fixing hole system. Non-handed. Slide channel assembly with integral electro-mechanical hold-open, 24 V DC, conforming to EN 1155. Hold-open point (80° – 140°) and pull-off force infinitely variable. One-piece cover. Overall height 30 mm.

Approved by the German Institute for Building Technology, Berlin, for use in hold-open systems. Acceptance inspection of the system is mandatory.

Colour

- silver
- white, sim. to RAL 9010 9016
- stainless steel
- special colour (sim. to RAL)

Make

TS 93G EMF,
EN 2-5

TS 93 EMR EN 2-5

Cam action door closer conforming to EN 1154, carries the CE mark, Contur design, with rapidly decreasing opening torque/force. Pull-side fixing. Closing speed, latching speed, hydraulically controlled backcheck and delayed action conveniently adjustable at valves accessible from the front. Mounting bracket with universal fixing hole system. Non-handed. Slide channel assembly with integral smoke detector featuring standby and maintenance indicators and electro-mechanical hold-open, 24 V DC, conforming to EN 1155.

Hold-open point (80° – 140°) and pull-off force infinitely variable. A floating (volt-free) alarm contact and connections for further detectors and external manual release devices are provided. One-piece cover. Overall height 30 mm. Approved by the German Institute for Building Technology, Berlin, for use as a hold-open unit. Acceptance inspection of the system is mandatory.

Model

- TS 93 EMR with integrated power pack. Power supply 230 V AC, operating voltage 24 V DC

Colour

- silver
- white, sim. to RAL 9010 9016
- stainless steel
- special colour (sim. to RAL)

Make

TS 93 EMR, EN 2-5

TS 93G EMR EN 2-5

Cam action door closer conforming to EN 1154, carries the CE mark, Contur design, with rapidly decreasing opening torque/force. Push-side fixing. Closing speed, latching speed, hydraulically controlled backcheck and delayed action conveniently adjustable at valves accessible from the front. Mounting bracket with universal fixing hole system. Non-handed. Slide channel assembly with integral smoke detector featuring standby and maintenance indicators, power pack and electro-mechanical hold-open, 24 V DC, conforming

to EN 1155. Hold-open point (80° – 140°) and pull-off force infinitely variable. A floating (volt-free) alarm contact and connections for further detectors and external manual release devices are provided. One-piece cover. Overall height 30 mm. Approved by the German Institute for Building Technology, Berlin, for use as a hold-open unit. Acceptance inspection of the system is mandatory.

Model

- TS 93G EMR with integrated power pack. Power supply 230 V AC, operating voltage 24 V DC

Colour

- silver
- white, sim. to RAL 9010 9016
- stainless steel
- special colour (sim. to RAL)

Make

TS 93G EMR, EN 2-5

RMZ

Smoke detector, Contur design, with standby and maintenance indicators, integral power pack and optical smoke sensor for transom/lintel fixing. For activation of dormakaba hold-open devices. A floating (volt-free) alarm contact and connections for further detectors and external manual release devices are provided.

Can be switched to manual reset. One-piece cover. Overall height 30 mm. Approved by the German Institute for Building Technology, Berlin, for use in a hold-open system. Acceptance inspection of the system is mandatory.

Model

- RMZ with integrated power pack. Power supply 230 V AC, operating voltage 24 V DC

Colour

- silver
- white, sim. to RAL 9010 9016
- stainless steel
- special colour (sim. to RAL)

Make

RMZ

RM-N

Optical smoke detector, 24V DC, for ceiling fixing. For use as second and third triggering detector on all dormakaba hold-open systems. With floating (no-volt) changeover contact. General building

approval granted by DIBt, Berlin and the VdS, Cologne; compliant to EN 54, Part 7. Acceptance inspection mandatory in Germany.

Colour

- white, sim. to RAL 9003

Make

RM-N

Specification text double doors

TS 93 GSR EN 2-5

Cam action door closer conforming to EN 1154, carries the CE mark, Contur design, with rapidly decreasing opening torque/force. Pull-side fixing. Closing speed, latching speed, hydraulically controlled backcheck and delayed action conveniently adjustable at valves accessible from the front. Mounting bracket with universal fixing hole system. Non-handed.

Slide channel assembly with integrated mechanical door co-ordinator, conforming to EN 1158. This system operates independently of the door closer hydraulics using a push rod clamping system with an overload release and one-piece cover. Overall height 30 mm. Non-handed.

Approved by the German Institute for Building Technology, Berlin, for use on fire and smoke check doors.

Colour

- silver
- white, sim. to RAL 9016
- stainless steel
- special colour (sim. to RAL)

Make

TS 93 GSR

TS 93 GSR-EMF EN 2-5

Cam action door closer conforming to EN 1154, carries the CE mark, Contur design, with rapidly decreasing opening torque/force. Pull-side fixing. Closing speed, latching speed, hydraulically controlled backcheck and delayed action conveniently adjustable at valves accessible from the front. Mounting bracket with universal fixing hole system. Non-handed. Slide channel assembly with integrated mechanical door co-ordinator, conforming to EN 1158. With electro-mechanical hold-open, 24 V DC, conforming to EN 1155.

Hold-open point (80° – 130°) and pull-off force infinitely variable. This system operates independently of the door closer hydraulics using a push rod clamping system with an overload release and one-piece cover. Overall height 30 mm. Non-handed. Approved by the German Institute for Building Technology, Berlin, for use in hold-open systems. Acceptance inspection of the system is mandatory.

Model

- TS 93 GSR-EMF 1
With electro-mechanical hold-open for the inactive leaf
- TS 93 GSR-EMF 2
With electro-mechanical hold-open for the active and inactive leaf
- TS 93 GSR-EMF 1G
With electro-mechanical hold-open for the active leaf

Colour

- silver
- white, sim. to RAL 9016
- stainless steel
- special colour (sim. to RAL)

Make

TS 93 GSR-EMF 1
TS 93 GSR-EMF 2
TS 93 GSR-EMF 1G

TS 93 GSR-EMR EN 2-5

Cam action door closer conforming to EN 1154, carries the CE mark, Contur design, with rapidly decreasing opening torque/force. Pull-side fixing. Closing speed, latching speed, hydraulically controlled backcheck and delayed action conveniently adjustable at valves accessible from the front. Mounting bracket with universal fixing hole system. Non-handed. Smoke detector with standby and maintenance indicators, fully integrated in the door co-ordinator body. A floating (volt-free) alarm contact and connections for further detectors and external manual release devices are provided.

Power supply 230 V AC, operating voltage 24 V DC. Slide channel assembly with integrated mechanical door co-ordinator, conforming to EN 1158. With electro-mechanical hold-open, 24 V DC, conforming to EN 1155. Hold-open point (80° – 130°) and pull-off force infinitely variable. This system operates independently of the door closer hydraulics using a push rod clamping system with an overload release and one-piece cover. Overall height 30 mm. Non-handed. Approved by the German Institute for Building Technology, Berlin, for use as a hold-open unit. Acceptance inspection of the system is mandatory.

Model

- TS 93 GSR-EMR 1
With electro-mechanical hold-open for the inactive leaf
- TS 93 GSR-EMR 2
With electro-mechanical hold-open for the active and inactive leaf
- TS 93 GSR-EMR 1G
With electro-mechanical hold-open for the active leaf

Colour

- silver
- white, sim. to RAL 9016
- stainless steel
- special colour (sim. to RAL)

Make

TS 93 GSR-EMR 1
TS 93 GSR-EMR 2
TS 93 GSR-EMR 1G

TS 93 GSR/BG EN 2-5

Cam action door closer conforming to EN 1154, carries the CE mark, Contur design, with rapidly decreasing opening torque/force. Push-side fixing. Closing speed, latching speed, hydraulically controlled backcheck and delayed action conveniently adjustable at valves accessible from the front. Mounting bracket with universal fixing hole system. Non-handed.

Slide channel assembly with integrated mechanical door co-ordinator, conforming to EN 1158. This system operates independently of the door closer hydraulics using a push rod clamping system with an overload release and one-piece cover. Overall height 30 mm. Non-handed.

General building approval issued by the German Institute for Building Technology, Berlin, for use on fire and smoke check doors.

Colour

- silver
- white, sim. to RAL 9016
- stainless steel
- special colour (sim. to RAL)

Make

TS 93 GSR/BG

TS 93 GSR-EMF 2/BG EN 2-5

Cam action door closer conforming to EN 1154, carries the CE mark, Contur design, with rapidly decreasing opening torque/force. Push-side fixing. Closing speed, latching speed, hydraulically controlled backcheck and delayed action conveniently adjustable at valves accessible from the front. Mounting bracket with universal fixing hole system. Non-handed. Slide channel assembly with integrated mechanical door co-ordinator, conforming to EN 1158.

With electro-mechanical hold-open for the active and inactive leaf, 24 V DC, conforming to EN 1155.

Hold-open point (80° – 120°) and pull-off force infinitely variable. This system operates independently of the door closer hydraulics using a push rod clamping system with an overload release and one-piece cover. Overall height 30 mm. Non-handed. Approved by the German Institute for Building Technology, Berlin, for use in hold-open systems. Acceptance inspection of the system is mandatory.

Colour

- silver
- white, sim. to RAL 9016
- stainless steel
- special colour (sim. to RAL)

Make

TS 93 GSR-EMF 2/BG

TS 93 GSR-EMR 2/BG EN 2-5

Cam action door closer conforming to EN 1154, carries the CE mark, Contur design, with rapidly decreasing opening torque/force. Push-side fixing. Closing speed, latching speed, hydraulically controlled backcheck and delayed action conveniently adjustable at valves accessible from the front. Mounting bracket with universal fixing hole system. Non-handed. Smoke detector with standby and maintenance indicators, fully integrated in the door co-ordinator body. A floating (volt-free) alarm contact and connections for further detectors and external manual release devices are provided. Power supply 230 V AC, operating voltage 24 V DC.

Slide channel assembly with integrated mechanical door co-ordinator, conforming to EN 1158. With electro-mechanical hold-open for the active and inactive leaf, 24 V DC, conforming to EN 1155. Hold-open point (80° – 120°) and pull-off force infinitely variable. This system operates independently of the door closer hydraulics using a push rod clamping system with an overload release and one-piece cover. Overall height 30 mm. Non-handed. Approved by the German Institute for Building Technology, Berlin, for use as a hold-open unit. Acceptance inspection of the system is mandatory.

Model

- TS 93 GSR-EMR 2/BG
With integrated electro-mechanical hold-open for the active and inactive leaf.

Colour

- silver
- white, sim. to RAL 9016
- stainless steel
- special colour (sim. to RAL)

Make

TS 93 GSR-EMR 2/BG